

C.D.S. CONSULTANTS
Surface finishing equipment consultants
BWLCH TOCYN FARMHOUSE
BWLCH TOCYN
ABERSOCH
PWLLHELI
GWYNEDD LL53 7BN
EMAIL:Cdsconsultants@btinternet.com

TEL 01758 71 2245
FAX 01758 712014
MOBILE 07887 513614

SAFETY INSTRUCTIONS MOBILE BLAST POTS
STANDARD UNITS; PREPARED FOR EURO TRADING
BLASTING SYSTEMS

WARNING

1. Depressurise unit before reloading and depressurise unit **AND** isolate from compressed air supply **BEFORE** any maintenance procedure.
2. **To prevent delayed lung injury do not use abrasives containing free silica.**
3. Furnish all personnel in the area with approved respiratory equipment, eye and ear protection and ensure that these are worn.
4. Never connect the pot to a compressed air supply in excess of the Safe Working Pressure of 115p.s.i.
5. **DANGER** When using mobile diesel air compressors, always site the compressor away from the blast area and outside in a well ventilated area, to avoid any exhaust fumes being drawn into the compressor air intake. All standard breathing air filters **DO NOT** remove carbon monoxide from the air supply.
6. Read the recommended safety practices below.

SAFE PRACTICES

1. Never attempt to perform any maintenance while the unit is under pressure or is even capable of being pressurised. This means at a minimum the inlet ball valve should be closed and ideally the air source be shut off or disconnected.
2. Wear suitable eye protection when filling the unit. There is possibility that some abrasive may be blown back as the pop-up valve seats.
3. Always keep fingers well clear of the working area of the pop-up valve.
4. Periodically check all hoses to see that they are in good condition. Repair any valves or hoses that show signs of wear or leakage.
5. Check daily the blast nozzle. Replace immediately if any cracks however slight have appeared to avoid any possible disintegration of the nozzle.
6. All blast hose couplings and some air hose couplings are provided with holes through which a wire or a pin should be inserted to prevent accidental disconnections.
7. The interior condition of the vessel should be inspected regularly for corrosion.

8. All blast operators should be supplied with and use approved respiratory equipment, protective clothing, helmet, ear protection and gloves.
9. Whilst wearing standard blast cleaning helmets always ensure that;
 - a. A Filtered Air Supply is used.
 - b. A correctly fitted inner shatterproof visor is used to ensure operator eye protection.
 - c. A disposable external visor is fitted to protect the inner visor.
 - d. Ear plugs or ear defenders are worn for additional ear protection.
This information relates only to the noise level generated internally as a result of the introduction of breathing air. Additional ear protection may also be necessary if noise levels generated externally are above permitted levels.

OPERATING INSTRUCTIONS

SAFETY EQUIPMENT OPEN BLASTING

1. Connect the helmet air line to the breathing air filter on the pot and to the blast helmet. Wear protective clothing, gloves and ear protection.
2. Always ensure that the helmet is securely closed before the operator enters the blasting area. Always fit thick inner visor as well as expendable outer visor.

TO FILL

1. As a safety precaution it is recommended that the safety stop petcock fitted to the return side of the remote control valve should be opened prior to filling. This will prevent the operator from turning the unit on while the unit is being filled. This petcock is situated opposite the remote line return connection. The safety stop position is when the petcock is open to allow air to escape from the remote control valve, or the return deadman line.
2. Dump abrasive into the top head dish, being careful not to get pieces of the bag etc. into the pot. An excessive amount of material piled on top of the pop-up valve after the unit is full may prevent the pop-up valve from closing properly. **KEEP FINGERS CLEAR** of the pop-up valve. Only use dry abrasive.

TO BLAST

1. Connect the remote hoses to the connections on the remote control valve. The lower connection is supply air and the upper connection is the return air from the deadman handle. Be sure that the lever on the deadman handle is **NOT** depressed. Always check before connecting remote lines. **DANGER** – some deadman's handles must be connected the correct way round - check for the type of handle which you are using.
2. Ensure that the choke valve is open.
3. Open the inlet ball valve, if fitted.
4. Close the safety stop petcock.
5. Depress the deadman handle. Air and abrasive flow will come on in the blast hose.
Direct nozzle towards work pieces. **NEVER TOWARDS PERSONNEL.**
6. The abrasive flow can be adjusted with the control knob on the abrasive metering valve. Turn clockwise for less abrasive and counter clockwise for

more abrasive. Due to the length of the blast hose there will be a slight delay in control of the abrasive at the nozzle so allow a few seconds before adjusting further. Adjust gradually, and only to ensure minimum amount of abrasive is introduced to suit work requirement.

7. The bleed off on the bottom of the moisture separator should be kept slightly open to permit moisture to drain off. Once each day open it completely to blow out any dirt that might have accumulated.
8. At any time that the unit is connected to the compressed air supply but is not being used it is recommended that the safety stop petcock on the remote control valve is opened to prevent accidental activation of the control system.

HOW THE SYSTEM WORKS

Air pressure passes from the supply hose to the deadman handle, when activated the air travels back down the return hose. The return hose is connected to the operating chamber of the remote control valve. When air enters the remote control valve through the return hose, this activates the valve allowing air to enter the pot and blast hose and also the exhaust section of the valve preventing air escaping from the blast pot. The abrasive valve allows abrasive to fall into the air stream. When the deadman valve is released it vents the control pressure to the remote control valve allowing the air valve to return to its “normally closed” position. This halts the air supply to the blast hose and pot, at the same time opens the exhaust and vents the air in the pot to the atmosphere.

TROUBLE SHOOTING

A – Air Blast but No Abrasive

1. The pot is empty
2. The abrasive in the pot is wet. Try closing the choke valve on the vertical pipe on the side of the pot whilst blasting is taking place for one/two seconds at a time until some abrasive is pumped out. Operating the unit in the “choked” condition will allow the use of media that is too damp to flow properly, but it greatly accelerates wear in the abrasive metering valve. Continuous running in the “choked” position also reduces productivity and therefore should be avoided if possible.
3. Foreign matter is plugging the abrasive metering valve. Try closing the choke valve and opening the abrasive metering valve momentarily to see if that will blow the obstruction out. If that does not work then it will be necessary to depressurise the pot and remove the obstruction by hand.
4. Exhaust not sealed fully.
5. Pop-up Valve not seating properly.

B – Reduced pressure at the Nozzle (with or without abrasive flow)

1. Insufficient air compressor.
2. Air hose too small.

3. Abrasive adjustment open too far.
4. Pop-up valve not seating properly.
5. Choke valve partially closed.
6. Exhaust not sealed fully.

C – Unit is Slow to Turn On or Will Not Turn On.

1. Air hose too small.
2. Insufficient air compressor.
3. Couplings on remote hoses loose or leaking.
4. Remote hoses are plugged. If the return hose is disconnected from the pot, there should be air pressure whenever the deadman valve is depressed.
5. Deadman valve is plugged. Only a weak air signal, or none at all, comes from the deadman valve when the return hose is disconnected.
6. Defective seals in the remote control valve.

D – Unit Turns On Accidentally

1. The lever on the deadman is worn. Replace the deadman valve immediately.
2. Deadman Lines connected the wrong way round on certain designs of deadman handle.

SERVICE AND MAINTENANCE

DAILY

1. Always empty pot completely when not in use. Abrasive left in the pot can become damp and may cause blockages.
2. Make regular checks to all connections. i.e. air line and blast hose, replace gaskets or couplings if wear is evident.
3. Replace pop-up valve and sealing ring if any evidence of wear.
4. Check wear on nozzle. Replace if necessary.
5. Remove exhaust air muffler if fitted and clean out.

WEEKLY

1. Check for wear or deterioration of blast hose by squeezing firmly by hand.
2. Clean out water separator element and bowl.
3. Check and replace if necessary breathing air filter elements.
4. Check internals of the abrasive metering valve. Replace liner or diaphragm or wear plate if they show signs of wear.

REGULARLY

1. Remove inspection door and clean out machine. Check and if necessary replace door gasket.

EVERY 3 MONTHS MAXIMUM

1. Replace breathing air filter elements.

IMPORTANT

A blast pot is a pressure vessel and is subject to inspection as required by legislation. You should advise your insurers of your purchase and ensure that inspections are carried out, by a qualified person at specified intervals. Your insurers will advise on current legal requirements.

Parts List

1 1/4" REMOTE CONTROL VALVE – 1

<u>PART NO.</u>	<u>DESCRIPTION</u>
RCV-1	Remote Control Valve c/w Silencer
RCV1-1	Valve Body
RCV1-2	Bleed Off Housing
RCV1-3	Bleed Off Manifold
RCV1-4	Top Cover
RCV1-5	Inlet Valve
RCV1-6	Bleed Off Cylinder
RCV1-7	Piston
RCV1-8	Bottom Plate
RCV1-9	Diaphragm
RCV1-10	Piston Seal
RCV1-11	“O” Ring
RCV1-12	Packing
RCV1-13	1/4" Hexagon Brass Nipple (Remote Control Line)
RCV1-14	1/4" Hexagon Brass Nipple (Remote Line Feed)
RCV1-15	1/4" Ball Valve (If Fitted)
RCV1-16	Piston Screw
RCV1-17	3/4" Bleed Off Nipple
RCV1-18	Screw 8-25
RCV1-19	Silencer Housing
RCV1-20	Silencer Top Cover
RCV1-21	Silencer Bottom Plate
RCV1-22	Silencer Housing Pin
RCV1-23	Silencer Carriage
RCV1-24	Silencer Carriage Support
RCV1-25	Union Nut
RCV1-26	Nipple
RCV1-27	Silencer Nipple
RCV1-28	Silencer
RCV1-29	Nut
RCV1-30	Silencer Complete
RCV-1RK	Repair Kit

1 1/4" REMOTE CONTROL VALVE - I

Parts List / Drawing Reference as Suffix

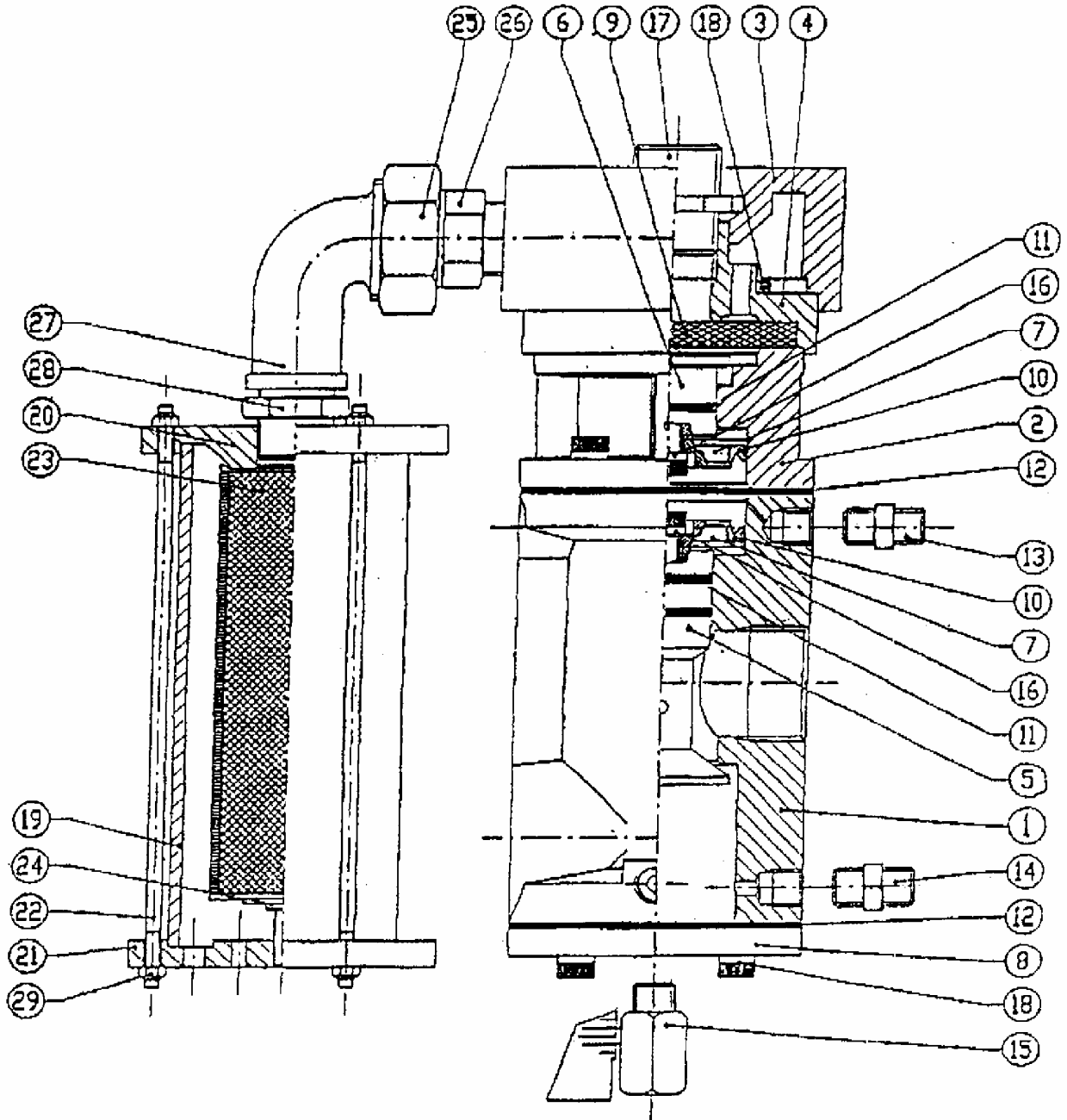

1" GRIT VALVE

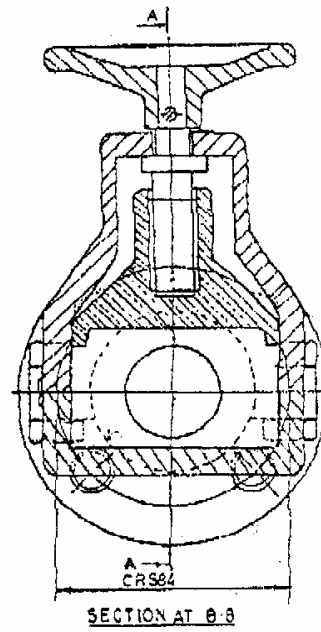
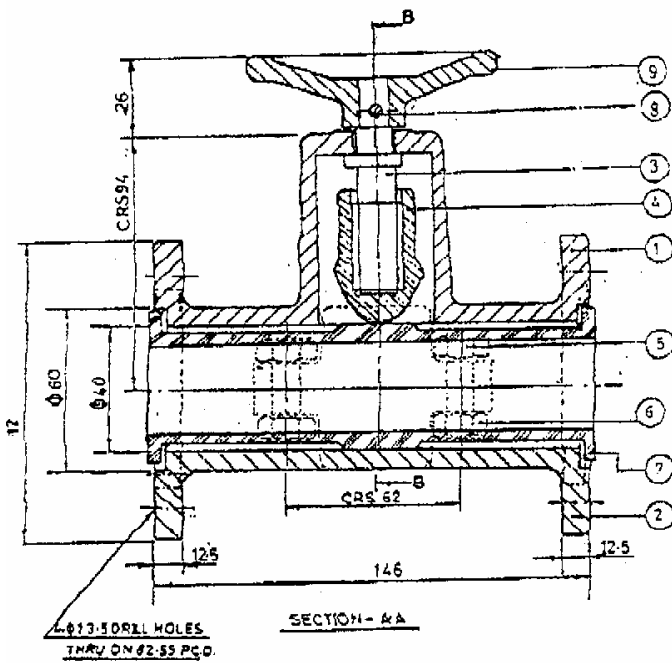

9	Handle	1	E/015F
8	Pin	1	
7	Rubber Liner	1	E/015E
6	Nuts M8x1.25	5	-----
5	Bolts M8x1.25 with spring washer	5	-----
4	Yoke	1	E/015D
3	Adjusting Screw	1	E/015C
2	Lower Half	1	E/015B
1	Upper Half	1	E/015A
	Assembly		E/015
Part no.	Description	Qty	Drg no

GV4
GV5
GV6

Lower flange with forged 'T'
Upper flange
Nuts and bolts for flanges (8 off) 1 set

Drawing reference

GV2A	(7)	1" Rubber Liner
GV10	(9)	Handwheel for 1" Valve
GV11	(3)	Mechanism for 1" Valve
GV20	(1)	Body only for 1" Valve (Upper)
GV23	(2)	Lower Body
GV24	(4)	Yoke
GV25	(5+6)	Bolts M8 x 1.25 + Nuts
GV26	(8)	Pin

1 1/2" WATTS TYPE WATER SEPARATOR

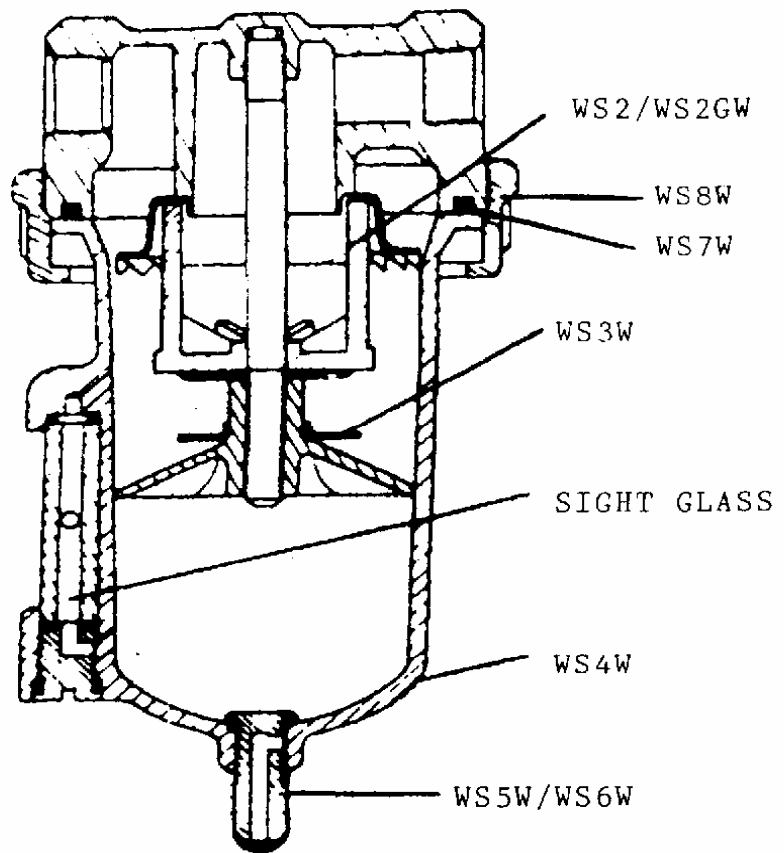

WS2W
WS2GW
WS3W
WS4W
WS5W
WS6W
WS7W
WS8W

Bronze Element Kit
Glass Element
Baffle Repair Kit
Metal Bowl Kit
Manual Drain Kit
Manual Draintap (Brass)
Bowl O-Ring
Bowl Retaining Ring

Sundry Parts

PCI
PVR1
PV1
PV2
HHG1
BV6

Large Pot Coupling c/w gasket
'O' Ring
Pop Up Valve complete with stem
Stem only for Pop Up Valve
Hand Hole Gasket
1 1/4" Ball Valve