

# C.D.S. CONSULTANTS

Bwlch Tocyn Farmhouse, Bwlchtocyn, Pwllheli Gwynedd LL53 7BN

Tel: 01758 712245 Fax: 01758 712014 Mobile: 07887 513614

www.cdsconsultants.co.uk ~ info@cdsconsultants.co.uk

---

## TURBINES

We have collaborated with an organisation in the UK who are specialist in the power plant supply industry having over 50 years expertise in the provision of steam, electricity, generation, design and project management

We have highly qualified and experienced team from steam boiler plant, combined heat and power, turbine and engine packages, installations, project management and aftercare service and spares support.

The need to address micro power solution whilst using cheap bio fuel and highly innovative plant design meets all criteria of best available technology avoiding excessive cost.

### 1.8 GAS TURBINE ENGINE

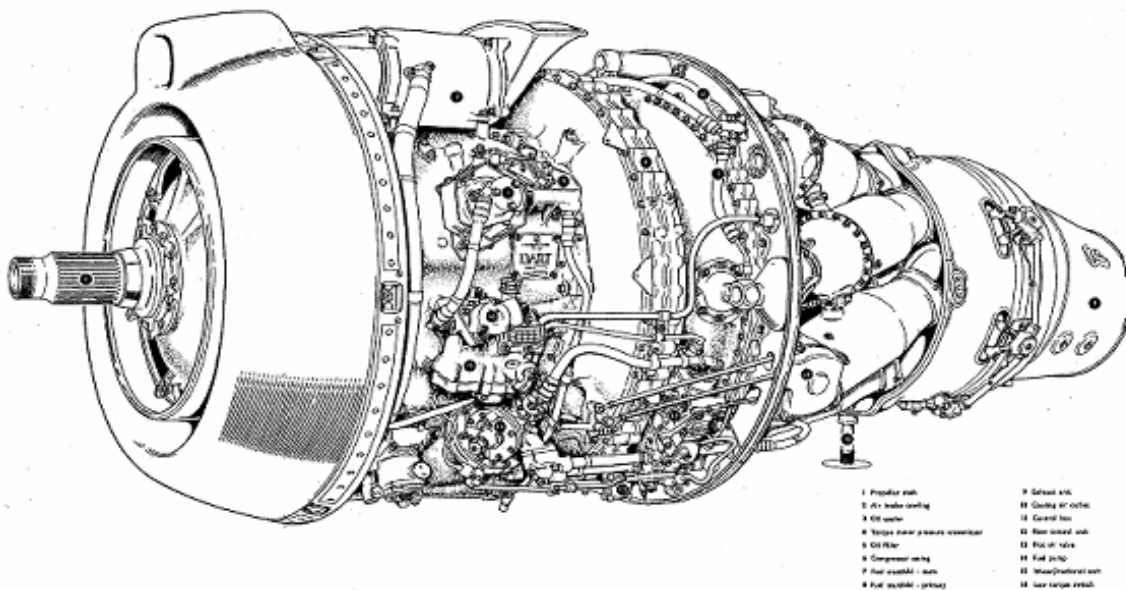

The module is totally self contained and is supplied in an easily transportable housing to provide electrical production in standard ranges of:-

- ? **0.8 KW**
- ? **1.8 KW**
- ? **2.5 KW**
- ? **500 KW**
- ? **800 KW**
- ? **1600 KW**
- ? **2500 KW**

# C.D.S. CONSULTANTS

Bwlch Tocyn Farmhouse, Bwlchtocyn, Pwllheli Gwynedd LL53 7BN

Tel: 01758 712245 Fax: 01758 712014 Mobile: 07887 513614

www.cdsconsultants.co.uk ~ info@cdsconsultants.co.uk

---

? 3500 KW

**Note:** Larger electrical outputs can be provided on request.

The GET2200 range of energy modules incorporate:-

- \* SPECIALLY DESIGNED AND CONSTRUCTED ACCOUSTIC ROOM
- \* TURBINE
- \* GEARBOX
- \* ALTERNATOR
- \* AIRCONDITIONING
- \* BATTERY START
- \* CONTROL ROOM
- \* SILENCER
- \* EXHAUST DUCTS
- \* LIGHTING AND MAINTENANCE SOCKETS
- \* FIRE PROTECTION
- \* FUEL AND ELECTRICAL METERING
- \* INTEGRAL CONTROL AND POWER WIRING

## Noise Level

The module is designed to restrict noise levels to less than 70 DbA and is encased in a specially insulated multi skin absorption system complete with sound proofed air inlet and outlet grills.



# C.D.S. CONSULTANTS

Bwlch Tocyn Farmhouse, Bwlchtocyn, Pwllheli Gwynedd LL53 7BN

Tel: 01758 712245 Fax: 01758 712014 Mobile: 07887 513614

www.cdsconsultants.co.uk ~ info@cdsconsultants.co.uk

---

The **GE Turbine** is robust and has an existing design life of 50 year. The engine has been modified to fire on a wide range of light grade fuel oils and biomass fuels and other low grade fuels.

In conjunction with its other components the overall design of this energy module is to produce electricity in the most efficient manner whilst reducing capital and installation costs.

**Quality** - The module is specifically designed as a composite electrical power generator and complies fully with all regulatory codes and safety recommendations.

The module is designed in accordance with safety codes for operation outdoors and requires external connection by others to:-

- \* Inlet fuel connection
- \* 415v electrical outlet
- \* Telemetry interface
- \* Clean air supply